

# Driven by efficiency.

Bosch technologies are used worldwide in almost all vehicles. People, and assuring their mobility, is what we are focused on.

Therefore, we have dedicated the last 125 years of pioneering spirit and expertise in research and manufacturing to achieving this.

We continue to work on our unique combination of solutions for spare parts, diagnostic devices, workshop equipment and services:

- ▶ Solutions for efficient vehicle repairs
- ▶ Innovative workshop equipment and software
- ▶ The world's most comprehensive range of new and replacement parts
- ▶ Large network of wholesale customers, for quick and reliable parts supply
- ▶ Competent hotline support
- ▶ Comprehensive educational and training offers
- ▶ Targeted sales and marketing support

#### Find out more at:

[boschaftermarket.com](http://boschaftermarket.com)

[f](#) Bosch Autoparts Singapore

[@](#) Boschautoparts\_sg

#### Robert Bosch (SEA) Pte Ltd

11 Bishan Street 21

Singapore 573943

Tel: (65) 62585511

[boschaftermarket.sg](http://boschaftermarket.sg)

Invented for life









## Bosch Mobility Aftermarket Brochure





# Contents

4 - 5	<b>Battery</b> Driven by Power	<small>100 Years Batteries from Bosch 1922 - 2022</small>	
6 - 7	<b>Battery Charger</b> Driven by Functionality		
10 - 11	<b>Braking System</b> Brake Discs Driven by Trust		
12 - 15	Brake Fluid Driven by Performance		
8 - 9	Brake Pads Driven by Safety		
16 - 17	<b>Filters</b> Air Filter Driven by Efficiency		
18 - 19	Cabin Filter Driven by Comfort		
20 - 21	Fuel Filter Driven by Robustness		
22 - 23	Oil Filter Driven by Reliability		
24 - 25	<b>Horn</b> Driven by Presence		
26 - 27	<b>Lighting</b> Driven by Visibility		
28 - 29	<b>Spark Plug</b> Driven by Ignition	<small>120 Years Spark plugs from Bosch 1902 - 2022</small>	
30 - 31	<b>Wiper</b> Driven by Clarity		



# Battery

Driven by Power

100 Years

Batteries from Bosch  
1922 – 2022



## Why Bosch Battery?

Modern cars today are fitted with features that require higher power than you think. With the increasing on-board electrical consumables, Bosch batteries provide consistent power supply ensuring the highest standards are met at all times.

### Benefits at a glance



**Extra Long Service Life**  
High density active material and optimized particle size for longer service life



**Start / Stop**  
Special negative additives are added to reduce the shrinkage of active materials which increases charging acceptance



**Extra High Performance**  
Small-sized windows of the expanded grid lowers resistance and improves conductivity for consistently high performance



**Higher Durability**  
Optimized negative grid alloy inhibits corrosion and prolongs the battery life cycle with a high depth of discharge



**Higher Depth of Discharge (DOD)**  
Suitable for additional electrical load prevalent in modern vehicles to give you the extra power needed

## What is an EFB battery?

Enhanced Flooded Batteries (EFBs) are built for higher performance and reliability than standard batteries. Designed to support entry level Start-Stop engines.

EFB also enhances starting performance for standard engines and meets the increasing electrical demands of modern vehicles.

EFB provides increased cyclic stability and faster recovery from deep discharge. EFB maintains power supply in Start-Stop vehicles and restarts in a fraction of a second.

## ST Hightec AGM / Passenger car

### AGM technology for Advanced Start-Stop systems

Start-Stop technology reduces fuel consumption and CO<sub>2</sub> emissions. In city traffic, the vehicle's electrical system consumes more power than the alternator can supply. Due to less charging opportunity in start-stop systems, it's crucial to have a battery that is able to recharge quickly with superior starting power to enable engine-off mode.



### Benefits at a glance



**Extra Service Life**  
**Special Lid Structure**  
▶ Double lid with labyrinth construction prevents water loss

**Wide Cast on Strap**  
▶ High vibration resistance minimizes shedding of active material

**Polypropylene Case**  
▶ Made of highly durable material that can withstand high internal pressure



**Absorbent Glass Mat**  
▶ Electrolyte absorbed by micro-porous glass separators eliminates acid spills and terminal corrosion  
▶ Optimized component compression minimizes loss of active material  
▶ Maximizes charge reaction due to evenly distributed electrolyte



**Assured Safety**  
▶ 100% leakage proof with AGM technology  
▶ Eliminates emission of gases due to the recombinant nature  
▶ Safety valves relieve excess pressure



**Centralized Grid Lug / Fine Mesh Grid**  
▶ Higher charging and discharging performance  
▶ Designed for maximum current flow and high charge efficiency  
▶ Made of Tin-Calcium material with high corrosion resistance  
▶ Low internal resistance translates into higher power output



Auxiliary
AGM
Mercedes Benz with dual battery system. Provides backup power in case of emergency
Absorbent Glass Mat (AGM)
AGM technology offers long service life and is highly resilient to deep discharges



Scan to view full catalogue of products



e-Catalogue

# Battery Charger

Driven by Functionality



## Why Bosch Battery Charger?

- ▶ Bosch battery chargers provide reliable starting power and increase the battery's service life.
- ▶ Buying a Bosch battery charger for home use thus pays off quickly for any driver – whether motorcycle, car or commercial vehicle driver.

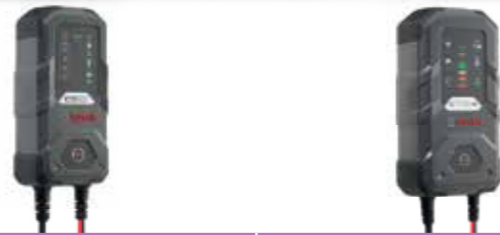

	C30	C70-B
	<b>Fast, efficient and versatile battery charging:</b> The C30 battery charger services 6 – 12 V lead acid, AGM, GEL, EFB and SLI batteries in scooters, motorcycles, cars, mobile homes and motorboats. The charger allows an easy one-button operation.	<b>The robust, modern battery charger C70-B</b> charges 12 – 24 V lead acid, AGM, GEL, EFB and SLI batteries in cars, mobile homes, commercial vehicles and motor-boats. The charger allows an easy one-button operation.
Types of batteries	6 V/12 V; lead acid, AGM, EFB, GEL and SLI	12 V/24 V; lead acid, AGM, EFB, GEL and SLI
Scope of application		
Max. charging current	3.5 A (±10 %)	6 A (±10 %)
One-button operation	●	●
Automatic charge control	●	●
Spark protection	●	●
Trickle charging	●	●
Short-circuit protection	●	●
Reverse-polarity protection	●	●
Overheating protection	●	●
Memory function	●	●
Power supply mode		●
Dust/splash water protection (IP 65)	●	●
Regenerative mode	●	●
Part number	0 189 911 030	0 189 950 070

### Advantages at a glance

- ▶ Power supply mode: while the battery is being serviced or replaced, the battery charger supplies the vehicle with energy so that no vehicle settings are lost
- ▶ Intelligent operation: The integrated micro-processor ensures faster charging times. The charger saves the last selected charging mode. Thereby, the charger can continue charging in the same mode in the event of a brief disconnection from the power supply.

### Standby mode:

In case of inactivity or a charging error, the device automatically switches to standby mode. The battery is not charged.

### Reverse polarity protection:

Lights up if the connection terminals are reversed

### Charging status indicators:

Display of charging progress in 4 stages of 25 % each.



### 6 V motorcycle and scooter mode

- ▶ Suitable for 6 V batteries (1.2 Ah – 14 Ah)
- ▶ 7.2 V/0.8 A charging

### Regeneration mode:

Slow pulse charging for gradual recovery of a deeply discharged battery

### 12 V motorcycle and scooter mode:

- ▶ Suitable for 12 V batteries (1.2 Ah – 14 Ah)
- ▶ 14.4 V/0.8 A charging

### Winter and AGM mode:

- ▶ Suitable for 12 V batteries (14 Ah – 120 Ah)
- ▶ Higher charging voltage
- ▶ 14.7 V/3.8 A charging

### 12 V car mode:

- ▶ Suitable for 12 V batteries (14 Ah – 120 Ah)
- ▶ 14.4 V/3.8 A charging



- ▶ Intelligent and automatic: The integrated microprocessor ensures faster charging times. The charger saves the last selected charging mode. Thereby, the charger can continue charging in the same mode in the event of a brief disconnection from the power supply.
- ▶ Fully automated and easy to use: simple one-button operation, LED light indicates charging progress
- ▶ High level of safety and durability: features overheating and short-circuit protection, protection against reversed polarity, IP65 dust- and splashwater-proof
- ▶ Features trickle charging and regenerative functions: the battery charger is suitable for winter breaks and for extending the service life

### Regeneration mode:

Slow pulse charging for gradual recovery of a deeply discharged battery

### Power supply mode:

Power supply of vehicle electronics without interruption when replacing the 12 V battery, so that no vehicle settings are lost

### Reverse polarity protection:

Lights up if the connection terminals are reversed

### Charging status indicators:

Display of charging progress in 4 stages of 25 % each.



### Standby mode:

In case of inactivity or a charging error, the device automatically switches to standby mode. The battery is not charged.

### 12 V mode motorcycle/car:

- ▶ Suitable for 12 V batteries (2 Ah – 230 Ah)
- ▶ 14.4 V/6 A charging

### 24 V mode:

- ▶ Suitable for 24 V batteries (14 Ah – 120 Ah)
- ▶ 28.8 V/3 A charging

### Winter and AGM mode:

- ▶ Higher charging voltage
- ▶ 12 V: 14.7 V/6 A charging (2 Ah – 230 Ah)
- ▶ 24 V: 29.4 V/3 A charging (14 Ah – 120 Ah)





# Brake Pads

Driven by Safety

## Why Bosch Brake pads?

**Top braking performance is achieved by selecting premium materials** and consistent testing of the pads. Research, development and production in state-of-the-art plants ensure the excellent quality demands offered by Bosch brake pads.



## Brake Pads Technology



### Advantages at a glance

- ▶ **Safe and reliable:** Bosch brake pads are subject to additional, voluntary tests that exceed statutory requirements
- ▶ **Consistent brake performance, even under high loads:** ensured by a stable friction value
- ▶ **Premium noise and judder behaviour:** through anti-vibration plates, chamfered edges
- ▶ **Comfortable and good pedal feel:** ensured by high compressibility
- ▶ **Always the right pad for the respective vehicle** selected by Bosch experts

### ? Did you know?

- ▶ Prior to assembly, lubricate the brake pad guides and brake caliper guides (depending on the model) with Bosch Superfit. Do not lubricate brake pads.
- ▶ Do not use lubricants containing copper.
- ▶ Replace accessory parts, springs, clips etc.

### ? Did you know?

Several US states will be specifying copper-free brake pads in the future to protect the environment. Bosch has already responded by registering the patent for the copper-free NAO brake pad mixture as early as 2014.



### i Bosch quality requirements

The ECE R90 quality standard represents the European guideline for approving disc brake pads and drum brake shoes. Brake pads from Bosch by far exceed statutory standards.



# Brake Discs

Driven by Trust

## Why Bosch Brake Discs?

Bosch has wide-ranging competence and many years of experience in the development and production of brake discs and is a reliable workshop partner. Bosch expertise is applied right from the selection of materials. This ensures products of outstanding Bosch quality that set standards in the market and convince workshop customers.



### Advantages at a glance \*

- ▶ **Reliable even in extreme situations:** due to premium performance and comfort features
- ▶ **Efficient and swift repairs:** through enclosed fixing screws, integrated wheel bearings and ABS sensor rings
- ▶ **Reduced braking noises and vibration behaviour support long term driving comfort:** through minimum manufacturing tolerances and the use of innovative alloyed and high-carbon cast materials
- ▶ **Corrosion-protected:** through innovative brake disc coatings

## Brake discs Technology

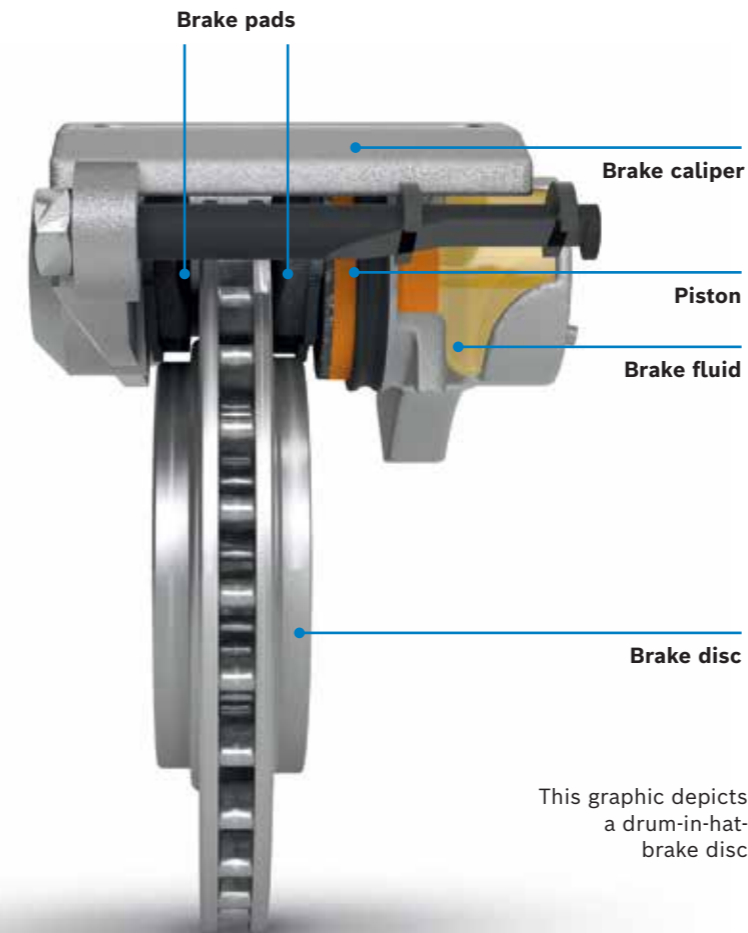

This graphic depicts a drum-in-hat-brake disc

### Disc brakes comprise:

- ▶ Brake disc firmly connected between the wheel hub to the wheel
- ▶ Brake bracket for securing the brake caliper
- ▶ Brake caliper
- ▶ Brake pads

### Specially matched brake components

Brake disc, bracket, caliper and pads are specially matched with each other and comply with the precise requirements of the respective vehicle model. This ensures top performance and safety in terms of:

- ▶ Brake efficiency
- ▶ Service life
- ▶ Braking comfort

### Cast steel – safe, reliable, appropriate

Higher engine performance and vehicle weights make increasing demands on the brake system. Only brake discs made from high-grade materials and a homogenous cast structure without internal tension comply with the vehicle manufacturers' specifications.

### Uncompromising precision: high carbon

High-carbon discs made from (gray cast iron with a higher carbon content) dissipate more heat compared to standard gray cast iron which minimize thermal cracks and distortions. This reduces brake judder. The higher carbon content leads to higher damping which helps to reduce noise.

**HIGH CARBON**

# DOT 4-Brake Fluid

Driven by Performance

## Why Bosch Brake Fluid?

Bosch DOT 4 brake fluid is suitable for the majority of all current vehicles. As a standard brake fluid, it meets the current standards in proven Bosch quality and protects the brake system from corrosion.



### Advantages at a glance

- ▶ **Long brake system service life:** Due to high-quality corrosion protection
- ▶ **High reliability:** Extensive testing beyond the standard specifications
- ▶ **High quality:** Due to high quality ingredients

### ! Workshop tip

- ▶ Always wear protective gloves and safety glasses and stick to the safety instructions!
- ▶ In case any brake fluid drops onto the vehicle paint, wash it off with a lot of water!
- ▶ Always dispose of brake fluid at specialized waste-management facilities!

# ENV6 Brake Fluid

Driven by Performance

## Why Bosch Brake Fluid?

**Highly dynamic brake fluid for high loads** – with its low viscosity and high wet boiling point, ENV6 already meets the requirements of future brake systems today.



### Advantages at a glance

- ▶ **One for all:** suitable for all standard vehicles (DOT 3, DOT 4, DOT 5.1 with or without ABS/ESP®)
- ▶ **Fast and safe braking:** exceeds all of the respective brake fluid standards
- ▶ **High performance:** ENV6 is the new standard at Bosch for current and future developments of new brake technologies
- ▶ **High vehicle stability, even for reactive braking:** the high-quality and viscous fluid ensures optimal response by the ABS and ESP® system
- ▶ **Longer maintenance intervals:** achieved by the high specifications (a brake fluid tester in the workshop helps in examining the boiling points)
- ▶ **Long storage capacity (min. 5 years when sealed well):** the tinplate packaging provides the brake fluid with extra protection against water absorption
- ▶ **Protects ABS and ESP® from wear and corrosion:** thanks to high lubricity of the brake fluid



# ENV6 brake fluid

## Quality tests

### Sophisticated tests at the Bosch development center

For more than two years, Bosch ENV6 has been tested and geared to new versions of the ABS and ESP® systems at the Bosch test-bench laboratory.

The Bosch ENV6 brake fluid has been subjected to extreme strains both in terms of test routines regarding the system-pressure build-up at extreme temperatures and wear and noise tests.



Bosch ENV6 test results at the laboratory: at the Bosch development center, the brake fluid is subjected to chemical tests.



Continuous-operation test benches at the high-tech laboratory: with its high dynamic, ENV6 contributes to the high performance and service life of modern brake systems.

### Comparing the viscosity and wet boiling point of different brake fluids

**Viscosity**  
[mm<sup>2</sup>/s]

The lower the viscosity, the shorter the reaction times of ESP®.

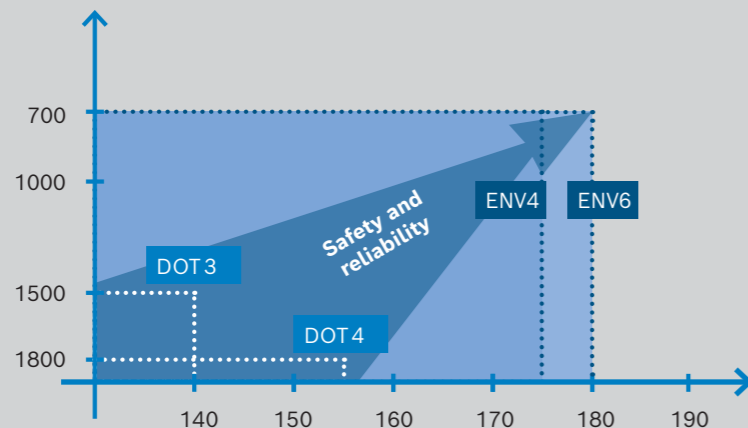

**High wet boiling point**  
[°C]

The higher the wet boiling point, the lower the risk of formation of vapour bubbles – cause of brake failure.

# Brake fluids

## Product range and Product details



	DOT 3	DOT 4	ENV6
	Bosch DOT 3 brake fluid is suitable for the majority of all current vehicles.*	Bosch DOT 4 brake fluid is suitable for the majority of all current vehicles.*	Bosch ENV6 sets new standards for DOT 4 brake fluids. It can replace all previous standard brake fluids on glycol base* (applies to vehicle models from 1990) and reduces the complexity in the workshop.
Dry boiling point (°C)	≥205	≥ 230	≥ 270
Wet boiling point (°C)	≥140	≥ 155	≥ 180
Viscosity at -40 °C (mm <sup>2</sup> /sec)	≤1500	≤ 1500	≤ 700
DOT types	DOT3	DOT 4	DOT 3, DOT 4, DOT 4 HP, DOT 5.1
Scope of application			
Compatibility ABS/ESP	Mostly used for older vehicle	ABS (1. Generation)	ABS + ESP
Performance	●○○○○	●●○○○	●●●●●
Container size (l)	0.5 / 1 / 5 / 20 / 60	0.5 / 1 / 5 / 20 / 60	0.5 / 1 / 5 / 20 / 60
Change interval **	2 Years or 40,000 km	2 Years or 40.000 km	3 Years or 60.000 km

#### Advantages at a glance

- Suitable for all hydraulic braking systems
- Long brake system service life: due to high-quality corrosion protection
- Suitable for all standard vehicles (DOT 3, DOT 4, DOT 5.1 with or without ABS/ESP®)
- New OE standard for some vehicle manufacturers and Bosch system development
- Longer maintenance intervals can be achieved

\* Not suitable for mineral oil or silicone based systems.  
\*\* Please always observe the manufacturer's information.



# Air Filter

Driven by Efficiency

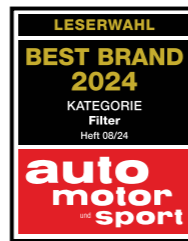

## Why Bosch Air Filter?

### Design and operation

on the example of an air filter with polyurethane frame

Microfiber filter medium with special resin impregnation

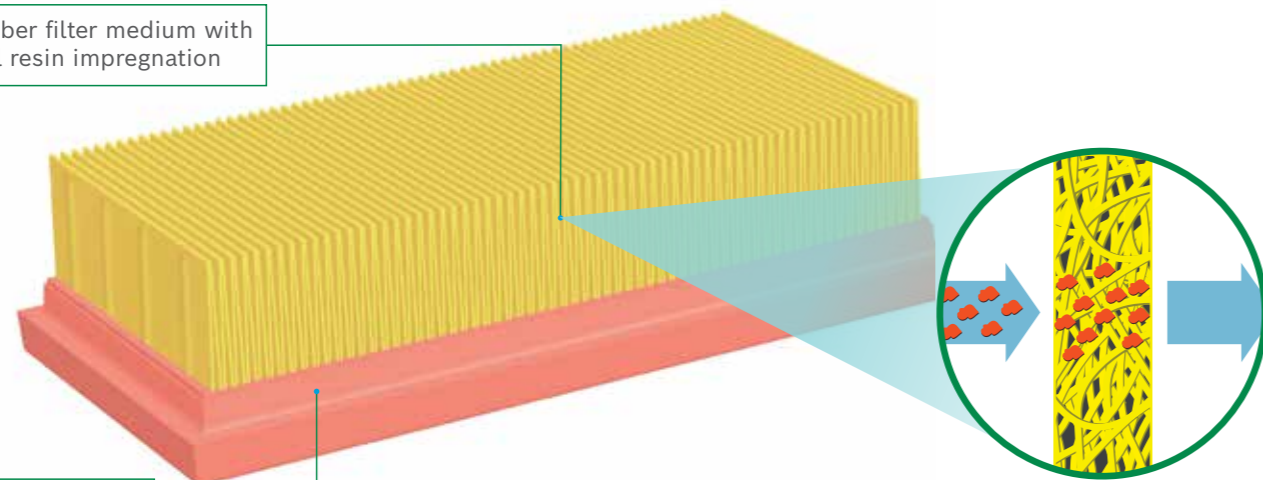

Sealing lip made of polyurethane

Filtration of dust and dirt particles



Bosch air filter protect the engine and support a proper function of the sensors in the intake air duct. They reliably separate particles from intake air and contribute to optimum engine performance.



### Advantages at a glance

- ▶ Long service life, excellent filter efficiency, moisture resistance and tensile strength
- ▶ High dust holding capacity and low flow resistance
- ▶ Robust fold geometry
- ▶ Appropriate fit

### Possible consequences of silted-up filters:

- ▶ Increase fuel consumption
- ▶ Reduced engine power
- ▶ Increased pollutant emissions

### Hot-film air mass meter for precise mixture preparation

- ▶ Sensors measuring the mass intake of air
- ▶ Sends information to the engine control unit for an exact mixture preparation
- ▶ Fitted at the intake duct behind the air filter

### For flawless operation, they need:

- ▶ Clean air
- ▶ Constant airflow without any disruptive turbulences



### Workshop tip:

Change air filters regularly as specified by the vehicle manufacturer!



### Did you know?

To burn one liter of fuel, a combustion engine needs 10,000 liters of clean air.



Scan to view full catalogue of products



e-Catalogue

# Cabin Filter

Driven by Comfort

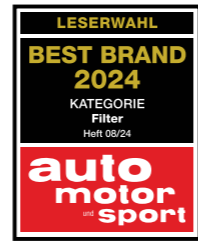

## Why Bosch Cabin Filter?

- ▶ Provides relief as allergic reactions can be annoying when driving
- ▶ Bosch cabin filters provide relief
- ▶ Traps allergens, bacteria and fine dust before reaching the car cabin
- ▶ Market coverage of 95%

## Specifications

Anti-allergic effect

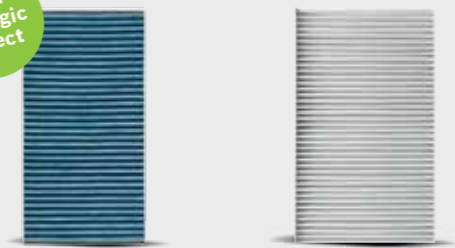

Function	Aeristo Premium	Aeristo (Standard)
	Anti-allergic and anti-bacterial effects	Clean air inside the car
Neutralizes allergens and bacteria	•	
Separates fine dusts (up to 99% of PM <sub>2.5</sub> µm)	•	
Separates foul-smelling and harmful gases (ozone, smog, exhaust gases)	•	
Separates pollen and fine dusts (up to 100% of PM <sub>10</sub> µm)	•	•
Protects the air conditioning	•	•
Reduces dazzling effects	•	•
Coverage		

### Possible consequences of silted-up filters:

- ▶ Poor vision due to misted windows, reducing safety
- ▶ Increased pollutants in the car
- ▶ Allergic reactions
- ▶ Restricted operation of air conditioning system due to deposits

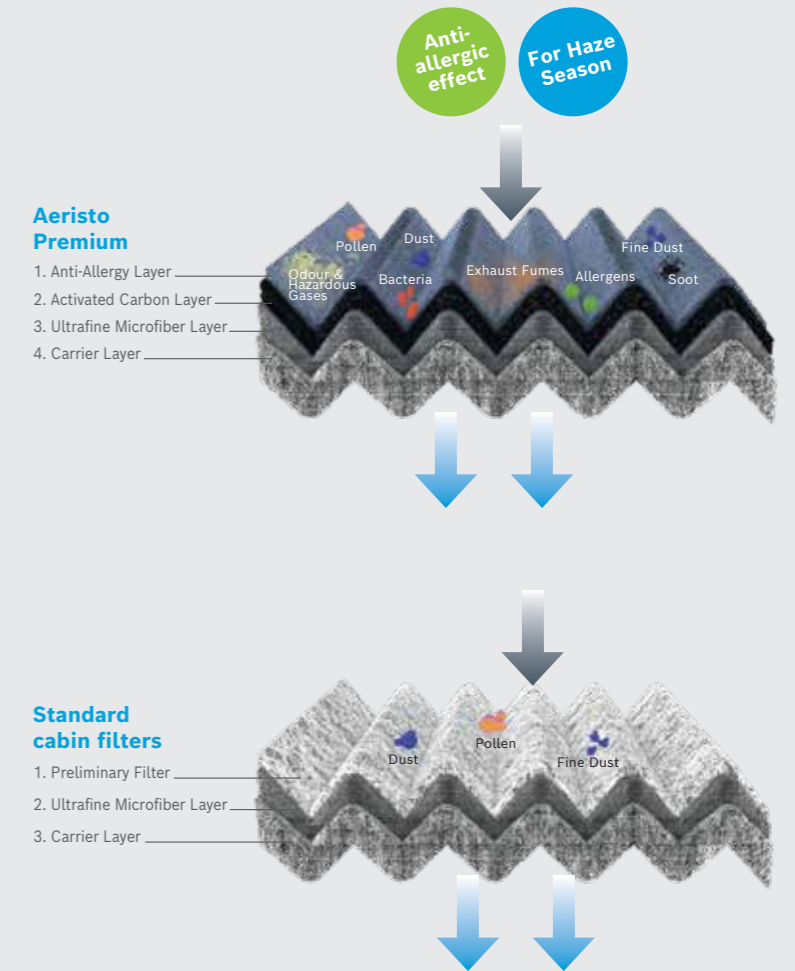
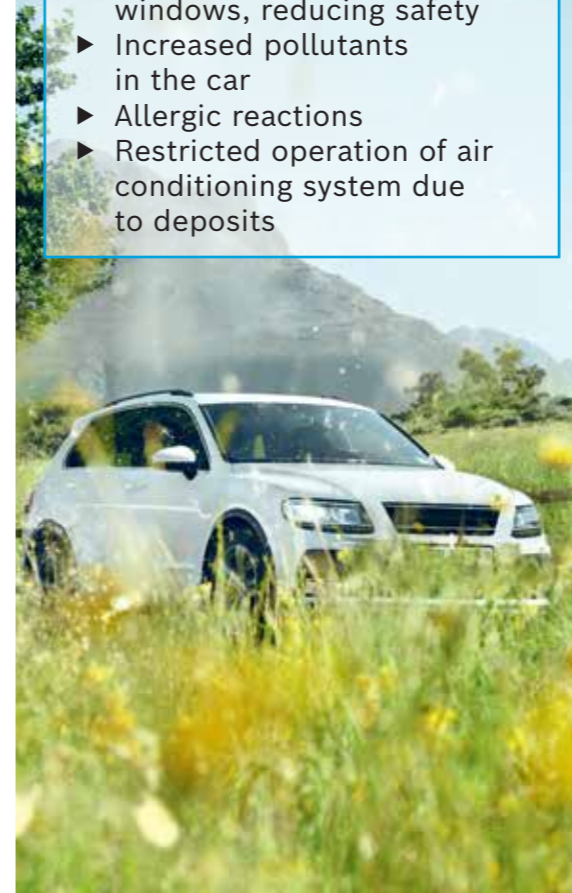

**Workshop tip:** Bosch recommends changes of cabin filters every 15,000 km or yearly.

**Did you know?** Allergies are on the rise. In Germany, approximately 16%\* of the population suffer from pollen allergies.  
\*Source: www.daab.de



Scan to view full catalogue of products



e-Catalogue



# Fuel Filter

Driven by Robustness

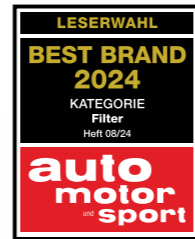

## Why Bosch Fuel Filter?

Bosch filters combine high-quality materials, meticulous processing and high development efforts. Tests at the laboratory reveal the differences between Bosch quality filters and cheap filters.

## Efficiency

Lower efficiency of cheap filters  
 → 6 times more particles get into the injection system!

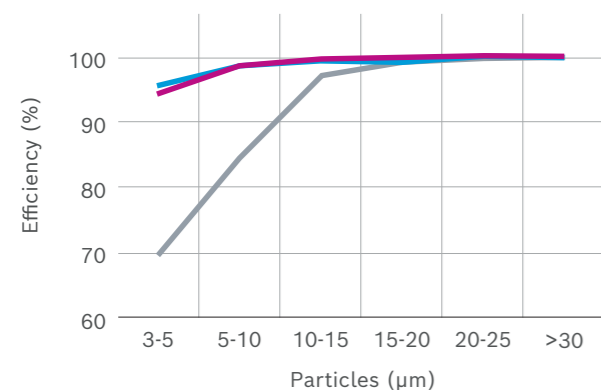

▶ Standard (ISO / TR 13353)  
 ▶ High-quality filter, e.g. Bosch  
 ▶ Low-quality filter

## Water separation

Water separation does not fulfill the standard requirements  
 → Risk of corrosion within fuel injection system!

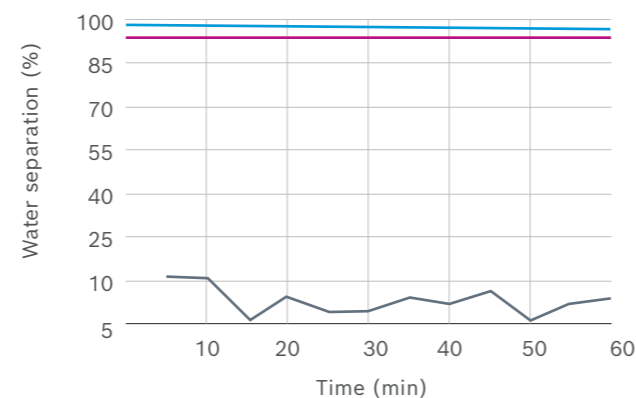

▶ Standard requirements (ISO / TR 16332)  
 ▶ High-quality filter, e.g. Bosch  
 ▶ Low-quality filter

## Cheap today, expensive tomorrow

With respect to fuel filters, those willing to save on the wrong things may risk expensive damage, for example to nozzles or the high-pressure pump.

### Cost relations

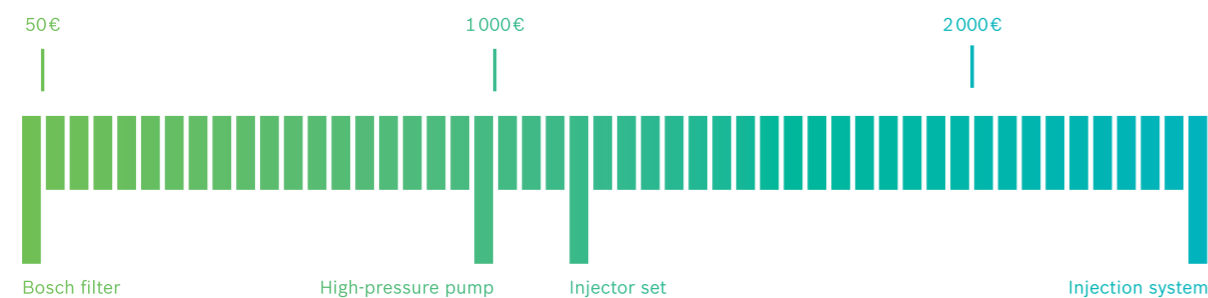

### On the safe side with Bosch filters

High particle separation rate thanks to microporous multilayer filter medium

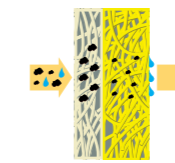

Large dust-holding capacity through high number of pleats

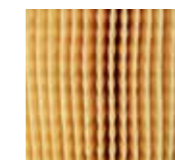

Reliable filtration thanks to stable pleat geometry



Corrosion-resistant housing prevents fuel leakages



Robust connection of the end pleats



High-quality seal made out of a special rubber prevents any fuel leakage



Protection cap on the clean side (outlet) of the filter to prevent any soiling during transport and storage



### Cheap filters – possible expensive consequences!

Low-quality filter medium  
 ▶ Increased engine wear  
 ▶ Injector clogging  
 ▶ Corrosion

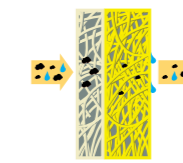

Lower number of pleats  
 ▶ Increased engine wear due to particles  
 ▶ Reduced service life

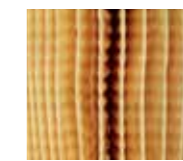

Unstable pleat geometry  
 ▶ Insufficient fuel filtration  
 ▶ Increased engine wear



Corrosion caused by spray water  
 ▶ Hazards caused by leaking fuel  
 ▶ Environmental pollution  
 ▶ Increased engine wear

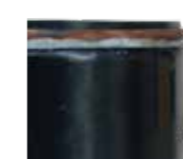

Bypass of unfiltered fuel caused by missing connection of end pleats  
 ▶ Increased engine wear



Damaged, porous seal  
 ▶ Hazards caused by leaking fuel  
 ▶ Environmental pollution



Missing protection cap facilitates filter soiling  
 ▶ Increased engine wear caused by dirt particles  
 ▶ Reduced filter service life



Scan to view full catalogue of products



e-Catalogue

# Oil Filter

Driven by Reliability



## Why Bosch Oil Filter?

- ▶ High particle holding capacity
- ▶ Reliable engine lubrication at almost all temperatures and oil pressures
- ▶ No oil leaks

## Advantages at a glance

Customer benefits	Product features
<b>Long service life of both filter and engine oil</b>	Microporous, specially impregnated filter medium
<b>High particle holding capacity</b>	Large filter surface
<b>High particle separation rate</b>	Specially designed and well balanced filter components
<b>Reliable engine lubrication at almost all temperatures and oil pressures</b>	Integrated bypass valve and backstop
<b>No oil leaks</b>	Seals made of a special rubber, corrosion-resistant housing materials

## Oil filter designs



### Oil filter insert

The oil filter housing is permanently connected to the engine block. When changing the filter, only the filter insert and the seals are replaced.



### Oil filter exchange box

When changing the filter, the entire oil filter is replaced and screwed right onto the engine block using a connector flange.

### Oil filters – types

#### Main flow filter

- ▶ With each cycle, all of the oil passes the filter

#### Combined main-flow/bypass filter

- ▶ 100 % of the oil is filtered by the main flow filter
- ▶ In addition, 10 % of the oil are subject to a fine filtration at the bypass filter – slowing down oil aging

## Bosch oil filters in comparison:

On the safe side with Bosch filters		Cheap filters – possible expensive consequences!
High particle separation rate thanks to microporous filter medium with special impregnation		Low-quality filter medium ▶ Increased engine wear ▶ Possible increase in fuel consumption
Large dust-holding capacity through large number of pleats		Low number of pleats ▶ Poor filtration ▶ Increased wear or even engine damage ▶ Reduced service life
Reliable filtration thanks to meticulous processing and stable pleat geometry		Unstable pleat geometry, excess of adhesives ▶ Increased engine wear ▶ Possible increase in fuel consumption
Corrosion-resistant housing prevents oil leakages		Corrosion caused by spray water ▶ Increased wear or even engine damage ▶ Environmental pollution caused by leaking oil
Robust felt ring prevents oil leakages		Poorly fitting felt ring ▶ Loss of internal integrity, poor filtration of oils ▶ Increased wear up to engine damage
High-quality seal made of a special rubber prevents oil leakages		Damaged, porous seal ▶ Increased wear or even engine damage ▶ Environmental pollution caused by leaking oil
Accurately set valve-opening pressure ensures reliable engine lubrication – even under cold conditions and in case of a clogged filter.		Poor functioning of the bypass valve ▶ Increased wear or even engine damage ▶ Bursting of the oil filter



Scan to view full catalogue of products



e-Catalogue



# Horn



Driven by Presence



## Why Bosch Horn?

- ▶ First patent worldwide for automotive horns
- ▶ ECE-compliant

## The Construction of Sound

Stage	Disc Horn	Fanfare Horn	Compressor Trumpet
<b>Sound Generation</b>	<ul style="list-style-type: none"> <li>▶ The armature collides with the core</li> <li>▶ Sound is being generated by impact of repeated metallic collisions</li> </ul>	<ul style="list-style-type: none"> <li>▶ Diaphragm vibrates repeatedly via free oscillation</li> <li>▶ Diaphragm design and trumpet length dictates pitch and timbre of sound</li> </ul>	<ul style="list-style-type: none"> <li>▶ Compressed air generated produces alternating air pressure states</li> <li>▶ Diaphragm oscillation results in an air column in trumpet</li> <li>▶ Movement of air column generates sound</li> </ul>
<b>Sound Amplification</b>	<ul style="list-style-type: none"> <li>▶ The vibrator creates sound by resonance</li> <li>▶ Sound is amplified by the tone disc</li> </ul>	<ul style="list-style-type: none"> <li>▶ Trumpet resonates and amplifies the sound</li> </ul>	<ul style="list-style-type: none"> <li>▶ Trumpet resonates and amplifies the sound</li> </ul>
<b>Sound Propagation</b>	<ul style="list-style-type: none"> <li>▶ Harsh metallic sound travels in straight line</li> <li>▶ Sound is projected forward</li> </ul> 	<ul style="list-style-type: none"> <li>▶ Harmonic and fuller sound propagates in fan-like pattern</li> <li>▶ Sound reach is wider, especially within near radius</li> </ul> 	<ul style="list-style-type: none"> <li>▶ Sound propagates in fan-like pattern with high volume strength</li> <li>▶ Wide sound reach</li> </ul> 

## The Acoustics Highs & Lows

### Frequency

Refers to the number of oscillations made by the diaphragm system per second. This determines the deep or high-pitched tone. Frequency is measured in hertz (Hz); 1 Hz equals to 1 oscillation per second.

If the oscillations are slow, frequency is low and deep. If it is rapid, frequency is high.

**Short wavelength**  
means lots of waves;  
high frequency,  
high-sound

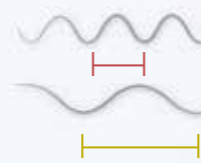

**Long wavelength**  
means fewer waves;  
low frequency,  
low sound

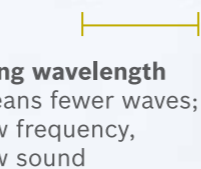

### Sound pressure / volume

Measured in decibels (dB), it relates to how far and fast the oscillating diaphragm system is being deflected during activation.

The distance heard depends on the direction of the sound wave, power and volume.

ECE standards call for all audible warning devices to have sound pressure of between 105 and 118 dB. All Bosch horns are within the range.

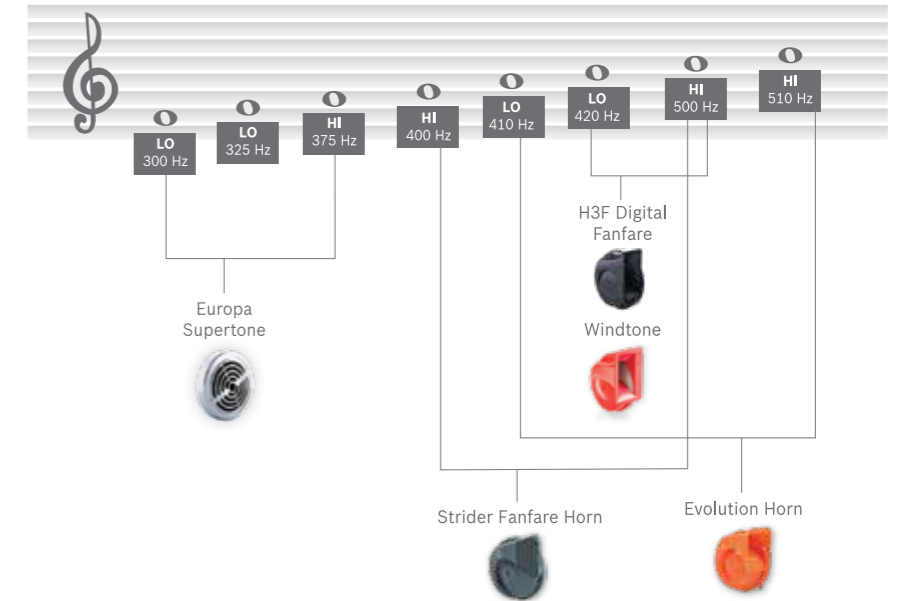

## Specifications

Models	DISC HORNS						FANFARE HORNS					COMPRESSOR TRUMPETS
	Europa Supertone	Piccolo	FC2 Disc Compact	Motorcycle Mini	FC4 Disc Standard	FD4 Disc Duty	H3F Digital Fanfare	Phantom Black Fanfare Horn	Evolution Fanfare Horn	Strider Fanfare Horn	Windtone	Trucker
RESISTANCE FACTORS	Weather-Resistant	✓		✓		✓	✓		IP54*	IP56*	IP56*	
	Impact-Resistant	✓				✓	✓					✓
	Corrosion-Resistant	✓	✓	✓	✓	✓	✓	✓	✓	✓	✓	✓
	EMC Protection	✓				✓	✓		✓	✓	✓	
	Teflon Filter	✓		✓		✓						
DESIGN & TUNING FACTORS	Compact Design		✓	✓			89mm	89mm	80mm +/-1	80mm +/-1		
	Serviceable				✓							
	Extra-high Durability		✓				✓			✓		
	Privileged Vehicles	✓										
	Suitable for external mounting	✓					✓	✓				✓

\* Mini option available

\*IP54 Protected from limited dust ingress, protected from water spray from any direction, limited ingress protection

\*IP56 Protected from limited dust ingress, protected from high pressure water jets from any direction, limited ingress protection



Scan to view full catalogue of products



e-Catalogue

# Lighting

Driven by Visibility

## Why Bosch bulbs?

Wide range of bulb products ranging from classic replacement to various high-performance options



Our products are in multiple packaging. Check with your local dealer or Bosch sales office for available packaging options.

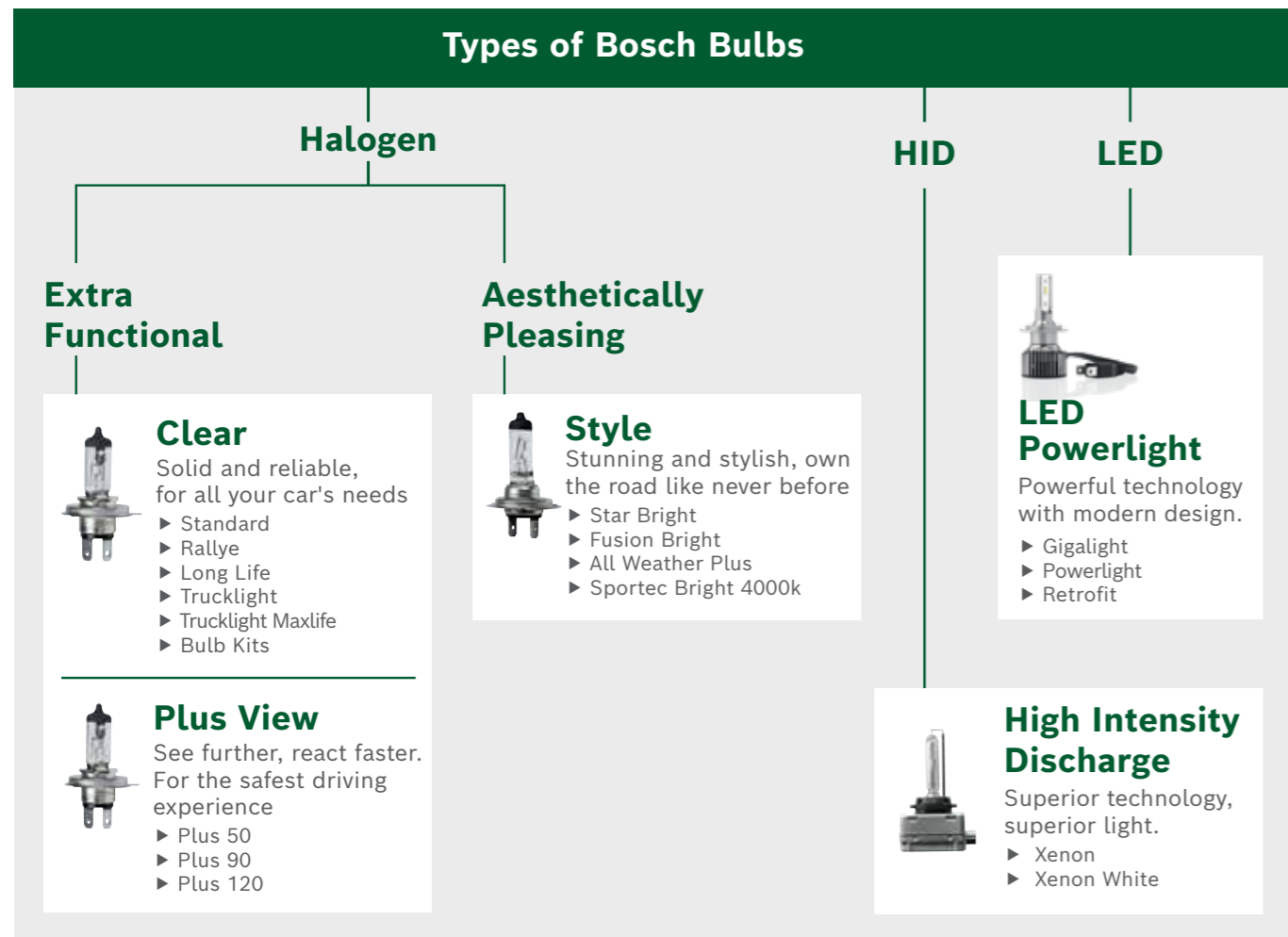

## LED Powerlight Technology

LED lattice chips for daylight bright light with up to 6,000 Kelvin

High beam

Low beam

Removable ring for easy installation

Integrated CAN bus to avoid error messages in the on-board computer

Aluminum heat sink with integrated fan for effective heat dissipation – for a long service life

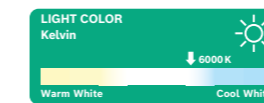
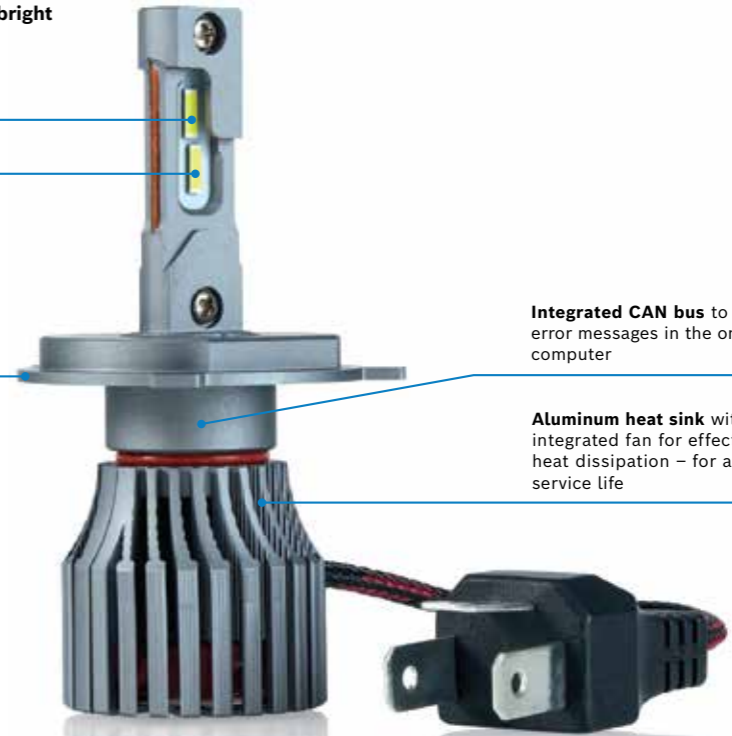

\* In comparison with standard halogen bulbs



Standard halogen bulb and Bosch LED Powerlight: street view (Bosch test lane) and front view in comparison at night

**Did you know?**

LED lamps (Light Emitting Diode) do not have a gas-filled glass body, but rather light-emitting chips. These are in the same position as the filaments of halogen bulbs – for optimal light distribution via the headlight reflectors. Compared to halogen bulbs, LED lamps have a significantly higher light output and a much longer service life. To prevent overheating, LED headlight lamps are equipped with a small cooling fan.

Scan to view full catalogue of products



e-Catalogue



# Spark Plug

**120 Years**  
Spark plugs from Bosch  
1902 – 2022

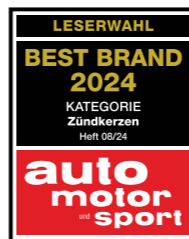

Driven by Ignition

## Why Bosch Spark Plug?

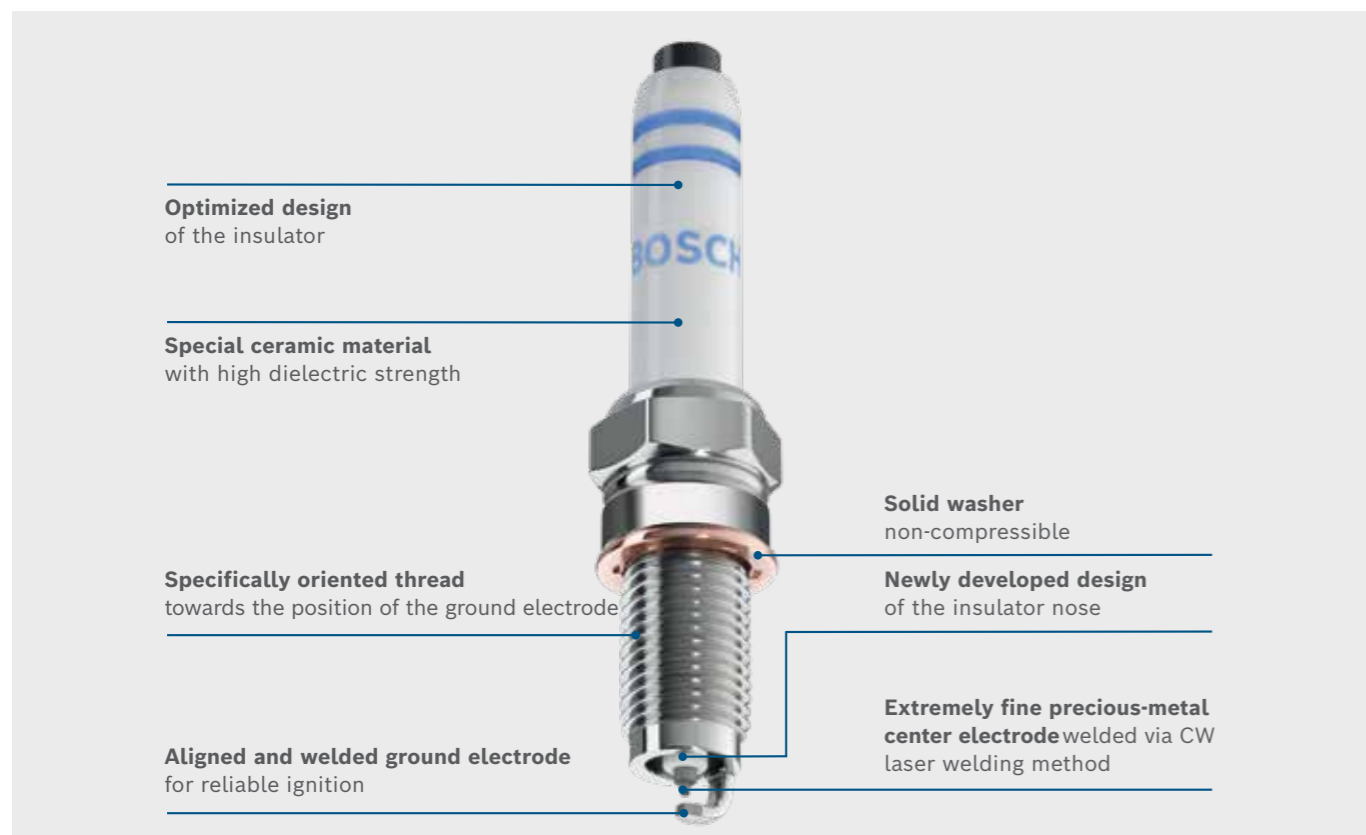

	Bosch Platinum	Bosch Double-Platinum	Bosch Iridium	Bosch Double-Iridium
<b>Scope of application</b>	Bosch Platinum, Double-Platinum, Iridium or Double-iridium spark plugs offer 1st class technology based on original equipment and engineered to the requirements of the respective engine.			
<b>Application</b>				
<b>Advantages at a glance</b>	<ul style="list-style-type: none"> <li>▶ Outstanding engine protection due to nickel-plated housing and thread</li> <li>▶ First-class ignitability for high performance</li> <li>▶ Hassle-free spark plug replacement</li> <li>▶ High wear resistance due to a highly heat-conductive center electrode</li> <li>▶ Reliable thermal characteristics due to heat-shrink assembly</li> </ul>			



### **i** Pin-to-pin spark plugs

- ▶ Tailored to gasoline engines with demanding flammability characteristics
- ▶ E.g. at high exhaust gas recirculation rates or lean air/fuel mixtures
- ▶ Two thin precious-metal electrodes ensure high energy transfer rates and reliable ignition



### **i** Solid washer

- ▶ Equip with a solid and non-compressible washer and a specifically oriented thread
- ▶ Tailored for engines with modern gasoline direct injection system
- ▶ The ideal alignment decides the accurate ignition of the fuel mixture



### **i** Cup terminal

- ▶ Features a longer insulator for improved flashover resistance
- ▶ Engines with reduced displacement or less cylinders and increased boost pressure need higher ignition voltage

### **!** Workshop tip:

#### Installation

1. Unbox
2. Screw in the spark plug by hand until it is seated at the cylinder head. Do not lubricate
3. Tighten with a spark plug wrench and the mandatory, type-specific torque, e.g. 23Nm



Scan to view full catalogue of products



e-Catalogue

# Wiper

Driven by Clarity

## Why Bosch Aerotwin?

**Intelligent adapter systems**  
► Facilitate easy fitting onto the wiper arm

**Aerodynamic spoiler**  
► Maintains firmly on windshield while keeping wind noise low especially at higher speeds

**Power Protection Plus coating**  
► Wiping without juddering or squeaking – even with extreme weather conditions

**Custom-made spring strips**  
► Outstanding wiping results with two parallel high-tech spring strips

## The Bosch Wipers Differences



**Perfect wiper performance**  
► Enhances wiper performance without leaving streaks or deposits  
► Delivers optimum visibility regardless of weather

**Longer service life**  
► Makes the lip of the blade robust and resistant, even under extreme heat or cold

**Gentle wiper action**  
► Reduces friction between blade and windshield  
► Less noise, shaking or buckling whether windscreen is wet or relatively dry

	Advantage Suitable for vehicles with hook-type wiper arms	Clear Advantage Suitable for vehicles with hook-type wiper arms	Aerotwin Retrofit Suitable for vehicles with hook-type wiper arms	Aerotwin Plus Suitable for vehicles with OE-type wiper arms
<b>Design</b>	Conventional Steel Design	Flat blade technology with mono steel spring	Flat Blade Technology with Double Evodium steel	
<b>Wiper-rubber Technology</b>	Tropicalized natural rubber		Synthetic rubber	
<b>Adapter System</b>	Pre-assembled original adapter		Pre-assembled original adapter	Modular system with 4 adapters to fit 10 types of wiper arms
<b>Installation</b>	★★★★★	★★★★★	★★★★★	★★★★☆
<b>Lifetime</b>	★★★	★★★★	★★★★★	★★★★★
<b>Wiping Performance</b>	★★★	★★★★	★★★★★	★★★★★
<b>High Speed</b>	★★★	★★★★	★★★★★	★★★★☆
<b>Silence</b>	★★★	★★★★	★★★★★	★★★★★

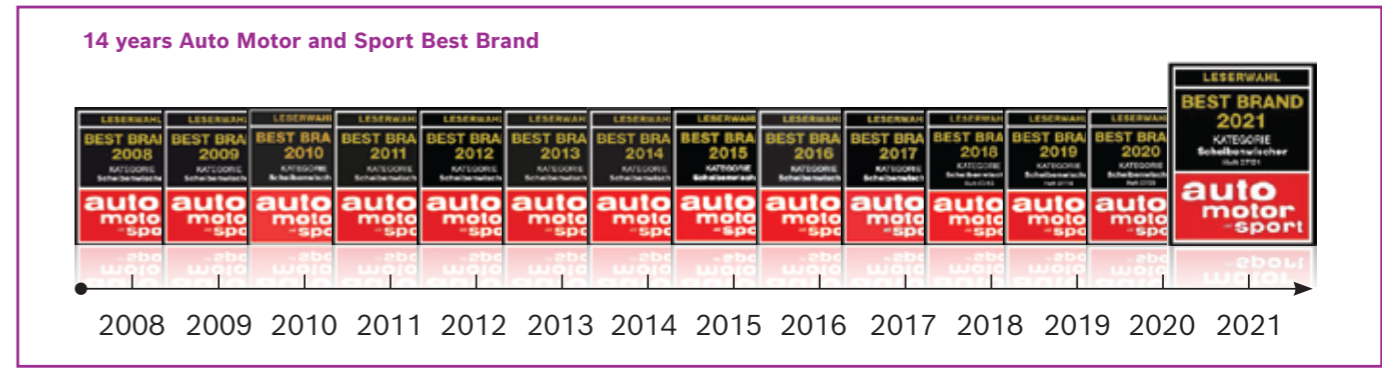

**Workshop tip:**  
Fitting is effortless

**Easy fitting:**  
Scan the QR code for installation video

**OR**  
Step-by-step assembly instructions

Scan to view full catalogue of products

e-Catalogue